

## Quality Indicators of Traditional Synchronization Systems

Ali S. Akayleh<sup>a</sup>, Emad S. Addasi<sup>b</sup>

Department of Electrical Power and Mechatronics Engineering, Tafila Technical University, Tafila, Jordan

<sup>a</sup>e-mail: akayleh\_em@yahoo.com

<sup>b</sup>e-mail: emad\_addasi@yahoo.com

*Received: December 28, 2015*

*Accepted: January 28, 2016*

**Abstract**— Synchronization systems are widely employed to connect multi-motor electric drive systems. Its main goal is to equalize the speeds of motors at different loads. In the current work, a comparative study between the different approaches of such synchronization systems has been done. Different indicators of three traditional synchronization systems were studied, modeled, calculated and discussed. These indicators affect the stability of the system and the synchronization system accuracy of operations. The three studied synchronization systems are: electrical shaft system, electromagnetic shaft system, and a capacitor-electromagnetic shaft system. Simulation is carried out using Matlab/Simulink. Simulation results show the differences, similarities, advantages and disadvantages of each of the three approaches. Therefore, the results may help choose the most suitable system for a certain application.

**Keywords**— Maximum synchronous angle, Maximum asynchronous torque, Maximum synchronous torque, Multi-motor synchronization, Stability indicators.

### I. INTRODUCTION

The most widely used motors in industry are the induction motors [1]. Electric motor drive systems consume most of the electrical energy produced. In the industrial countries, electric motors absorb about 65% of the entire electrical energy available of which only about 8% is taken up by dc motors [2]. In [3], authors made a comparison between a conventional proportional integral controller and sliding mode controller used for variable speed control with an indirect field orientation control method of an induction motor.

In general, synchronization systems are basically designed to adjust the speed of two or more induction motors with the existence of load differences allocated on their shafts. The main performance of synchronization systems is very much related to the synchronization capability: speed synchronization with maximum different loads on the motor shafts, and the required synchronization process time (recovery time).

Traditional multi-motor synchronization techniques are discussed in many works [4]-[7]. In [5], the authors studied the synchronization of multi- dc motor systems in textile and paper mills using microcontroller. In [7], a robust control strategy for the dual-motor electric drive system is developed by incorporating second order sliding mode control techniques.

Many industrial applications such as cranes, reel machines, and CNC (computer numerical control machines) [8], [9] have a multi-motor electric drive system. In such systems the driving motors drive loads simultaneously and, at the same time, stabilize their speeds. Good synchronization accuracy will improve the quality of the product [10], [11]. One of the synchronous control schemes used with multi-motor systems is cross-coupled control method [12], [13].

The most popular traditional synchronization systems are the synchronization systems with auxiliary machines, electrical shaft and electromagnetic shaft [3], [14]-[17]. Applications of synchronization control systems may be found in paper machines, offset printing and many

other different drives [18]-[20]. Different electromechanical motion systems, including crane applications were studied and investigated by several researchers [21]-[25]. The electrical shaft system consists mainly of two identical three - phase wound rotor type induction motors connected together by common additional external resistors in the rotor circuits, where the electromotive forces generated in these coils are moved towards the additional resistor as shown in Fig. 1 [8].

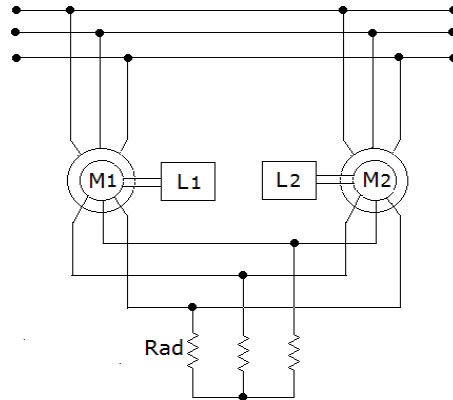

Fig. 1. Diagram of electrical shaft system

Additional resistors in the rotor common circuit play the most important role in the determination of the synchronous capability and recovery time of the system [14]. Synchronization systems with capacitor-electromagnetic shafts are the most recent applications compared to other synchronization systems; each motor is connected to a wounded coil on the steel cylinder (inductive rheostat element) which is very similar to transformer connections, where the primary coils are connected to one motor and the secondary to the other. It represents a synchronous drive with an electromagnetic shaft system and replaces an inductive rheostat element with a capacitor-inductive rheostat element, as shown in Fig. 2. The comprehensive analysis, modulation, and investigation of all above mentioned synchronization systems can be found in [1]-[7], and [13]-[19].

As mentioned, the synchronous process depends on the synchronization capability of the system [4]-[7], [14]-[17]; therefore, stability indicators of synchronization systems depend on parameters connected with the synchronous capability such as: maximum synchronous angle, maximum asynchronous torque, maximum synchronous torque and minimum required load. Relations and calculations of all stability indicators are found in [18].

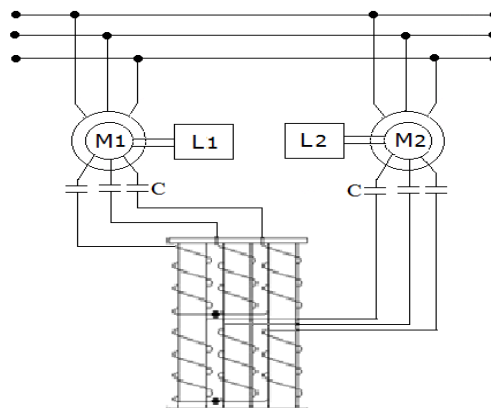

Fig. 2. Diagram of electromagnetic shaft system

In this work, modulation, calculation and investigation will be for low (slip < 0.2), medium (0.5 < slip < 0.2), and high (slip > 0.5) load applications using two identical three phase wound rotor induction motors: 5hp, 50Hz, 4pole, 380 Line voltage with ideal selected (rated and additional) parameters in each system [14]-[16]. The parameters of the motor under investigation are given in the appendix.

There are some parameters or indicators for each of the studied systems. This affects the stability of the system and the synchronization system accuracy of the operation. The main indicators are: maximum synchronous angle, maximum synchronous torque, minimum load, and maximum asynchronous torque. In this work, these indicators are studied for the three mentioned synchronization systems.

## II. ELECTROMAGNETIC INDUCED TORQUES OF SYNCHRONIZATION SYSTEM

In electrical, electromagnetic and capacitor-electromagnetic shaft synchronization systems, the general form of steady state torque equations can be written as [8], [9]:

$$T_1 = A + B \cos \alpha - D \sin \alpha \quad (1)$$

$$T_2 = A + B \cos \alpha + D \sin \alpha \quad (2)$$

where

$A$ ,  $B$  and  $D$  are constants;

$\alpha$  is the angular position between the rotor and the stator windings;

$T_1$  and  $T_2$  are the induced torque of the first and the second motors.

In electrical shaft systems, constants  $A$ ,  $B$  and  $D$  are found:

$$A = \frac{E_2^2}{2\omega_o} \left( \frac{\left(\frac{R'_2}{S}\right)}{\left(\frac{R'_2}{S}\right)^2 + (X_k)^2} + \frac{\left(\frac{R'_2 + 2R'_{ad}}{S}\right)}{\left(\frac{R'_2 + 2R'_{ad}}{S}\right)^2 + (X_k)^2} \right) \quad (3)$$

$$B = \frac{E_2^2}{2\omega_o} \left( \frac{-\left(\frac{R'_2}{S}\right)}{\left(\frac{R'_2}{S}\right)^2 + (X_k)^2} + \frac{\left(\frac{R'_2 + 2R'_{ad}}{S}\right)}{\left(\frac{R'_2 + 2R'_{ad}}{S}\right)^2 + (X_k)^2} \right) \quad (4)$$

$$D = \frac{E_2^2}{2\omega_o} \left( \frac{(X_k)}{\left(\frac{R'_2}{S}\right)^2 + (X_k)^2} - \frac{(X_k)}{\left(\frac{R'_2 + 2R'_{ad}}{S}\right)^2 + (X_k)^2} \right) \quad (5)$$

In electromagnetic shaft system, constants  $A$ ,  $B$  and  $D$  may be found as:

$$A = \frac{E_2^2}{2\omega_o} \left( \frac{\left(\frac{R'_2 + R'_o}{S}\right)}{\left(\frac{R'_2 + R'_o}{S}\right)^2 + (X_k + X'_o)^2} + \frac{\left(\frac{R'_2 + R'_o}{S} + \frac{2R'_M}{\sqrt{S}}\right)}{\left(\frac{R'_2 + R'_o}{S} + \frac{2R'_M}{\sqrt{S}}\right)^2 + \left(X_k + X'_o + \frac{2X'_M}{\sqrt{S}}\right)^2} \right) \quad (6)$$

$$B = \frac{E_2^2}{2\omega_o} \left( \frac{-\left(\frac{R'_2 + R'_o}{S}\right)}{\left(\frac{R'_2 + R'_o}{S}\right)^2 + (X_k + X'_o)^2} + \frac{\left(\frac{R'_2 + R'_o}{S} + \frac{2R'_M}{\sqrt{S}}\right)}{\left(\frac{R'_2 + R'_o}{S} + \frac{2R'_M}{\sqrt{S}}\right)^2 + \left(X_k + X'_o + \frac{2X'_M}{\sqrt{S}}\right)^2} \right) \quad (7)$$

$$D = \frac{E_2^2}{2\omega_o} \left( \frac{(X_k + X'_o)}{\left(\frac{R'_2 + R'_o}{S}\right)^2 + (X_k + X'_o)^2} - \frac{\left(X_k + X'_o + \frac{2X'_M}{\sqrt{S}}\right)}{\left(\frac{R'_2 + R'_o}{S} + \frac{2R'_M}{\sqrt{S}}\right)^2 + \left(X_k + X'_o + \frac{2X'_M}{\sqrt{S}}\right)^2} \right) \quad (8)$$

In capacitor-electromagnetic shaft, constants  $A$ ,  $B$  and  $D$  may be found as:

$$A = \frac{E_2^2}{2\omega_o} \left( \frac{\left(\frac{R'_2 + R'_o}{S}\right)}{\left(\frac{R'_2 + R'_o}{S}\right)^2 + (X_k + X'_o)^2} + \frac{\left(\frac{R'_2 + R'_o}{S} + \frac{2R'_M}{\sqrt{S}}\right)}{\left(\frac{R'_2 + R'_o}{S} + \frac{2R'_M}{\sqrt{S}}\right)^2 + \left(X_k + X'_o + \frac{2X'_M}{\sqrt{S}} - \frac{2X_C}{S^2}\right)^2} \right) \quad (9)$$

$$B = \frac{E_2^2}{2\omega_o} \left( \frac{-\left(\frac{R'_2 + R'_o}{S}\right)}{\left(\frac{R'_2 + R'_o}{S}\right)^2 + (X_k + X'_o)^2} + \frac{\left(\frac{R'_2 + R'_o}{S} + \frac{2R'_M}{\sqrt{S}}\right)}{\left(\frac{R'_2 + R'_o}{S} + \frac{2R'_M}{\sqrt{S}}\right)^2 + \left(X_k + X'_o + \frac{2X'_M}{\sqrt{S}} - \frac{2X_C}{S^2}\right)^2} \right) \quad (10)$$

$$D = \frac{E_2^2}{2\omega_o} \left( \frac{(X_k + X'_o)}{\left(\frac{R'_2 + R'_o}{S}\right)^2 + (X_k + X'_o)^2} - \frac{\left(X_k + X'_o + \frac{2X'_M}{\sqrt{S}} - \frac{2X_C}{S^2}\right)}{\left(\frac{R'_2 + R'_o}{S} + \frac{2R'_M}{\sqrt{S}}\right)^2 + \left(X_k + X'_o + \frac{2X'_M}{\sqrt{S}} - \frac{2X_C}{S^2}\right)^2} \right) \quad (11)$$

where

$R_2, X_K$ - rotor resistance and inductive reactance ( $X_K = X_l + X'_2$ ),

$E_2$ - induced phase voltage in the rotor,

$R_M, X_M$ - resistance and inductive reactance of magnetization branch of inductive rheostat element,

$R_o, X_o$ - resistance and inductive reactance of inductive rheostat element,

$S$ - Slip.

### III. MAXIMUM SYNCHRONOUS ANGLE

Maximum synchronous angle is the maximum phase angle between the internally induced voltages of the two rotor windings. It indicates the maximum load ability deference. The practically maximum synchronous angle for all synchronization systems can be found as follows:

$$\alpha_{\max} = \arctg \left| \frac{D}{B} \right| \quad (12)$$

Fig. 3 shows the value of the maximum synchronous angle for electrical shaft (ES), electromagnetic shaft (EMS) and capacitor-electromagnetic shaft (EMSC) systems. It shows that at low and medium-load application case (slip less than 0.7), the maximum synchronous angle was found in both ES and EMSC. At high-load application case, the maximum synchronous angle was clearly found in EMS and EMSC. In general, increasing the load leads to increasing the maximum synchronous angles.

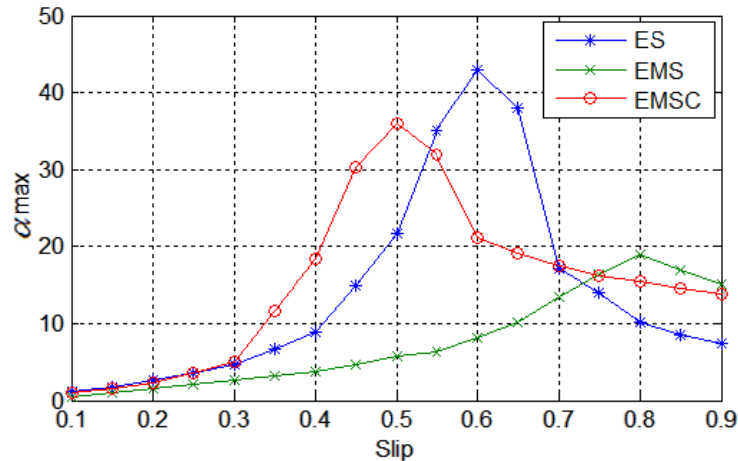

Fig. 3. Maximum synchronous angle versus slip

#### IV. MAXIMUM SYNCHRONOUS TORQUE

The maximum synchronous torque is considered the main stability indicator. It indicates the maximum synchronous capability of the system; and it can be found as the difference between motor torques at maximum difference of loads ( $L_1 \gg L_2$ ).

$$T_{sy} = T_2 - T_1 \quad (13)$$

In case of subtracting (1) from (2), the maximum synchronous torque becomes:

$$T_{sy} = 2D \sin \alpha \quad (14)$$

At low and medium load application cases the maximum synchronous torque and consequently maximum synchronous capability can be shown in EMSC and ES. The EMS system has a low synchronous capability with all load application cases, as it is shown in Fig. 4.

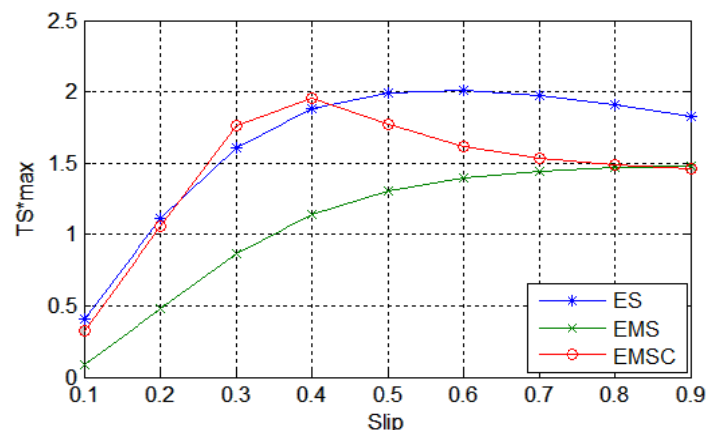

Fig. 4. Variations of the maximum synchronous torques with slip

### V. MAXIMUM ASYNCHRONOUS TORQUE

Maximum asynchronous torque indicates the maximum electromagnetic torque ability. The real maximum asynchronous torque is the sum of the motor torques at the minimum difference of loads ( $L_1 \approx L_2$ ).

$$T_{asy} = T_1 + T_2 \tag{15}$$

The maximum asynchronous torque may be found as:

$$T_{asy} = 2(A + B \cos \alpha) \tag{16}$$

Fig. 5 shows the maximum asynchronous torque for all synchronization systems. It shows that at a low load application case, the maximum asynchronous torque was found in both ES and EMS. In the medium load application case, increasing the slip value leads to increasing the asynchronous torque especially in EMSC. Fig. 6 illustrates the maximum asynchronous torque of the electrical shaft system at different slip values versus synchronous angles. The curves show that ES has a positive slop for slip values up to 0.6 at all values of the synchronous angle; this means that the system is stable and can get the synchronization. At the slip of 0.6, the ES system is critically stable. Analyses indicate that the critically stable points for EMS and EMSC are 0.8 and 0.9.

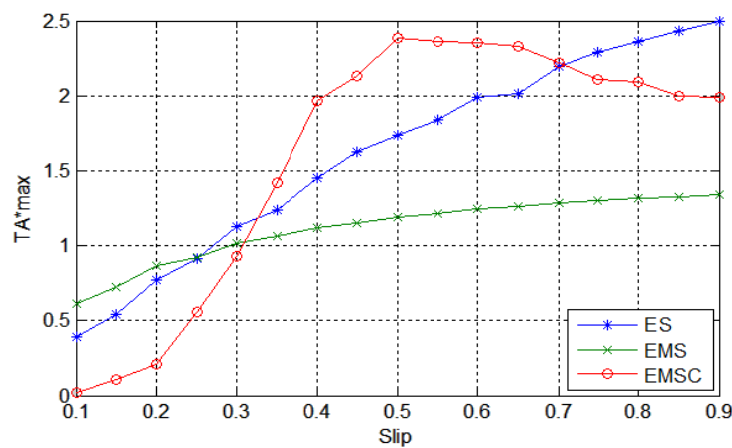

Fig. 5. Maximum asynchronous torque versus slip

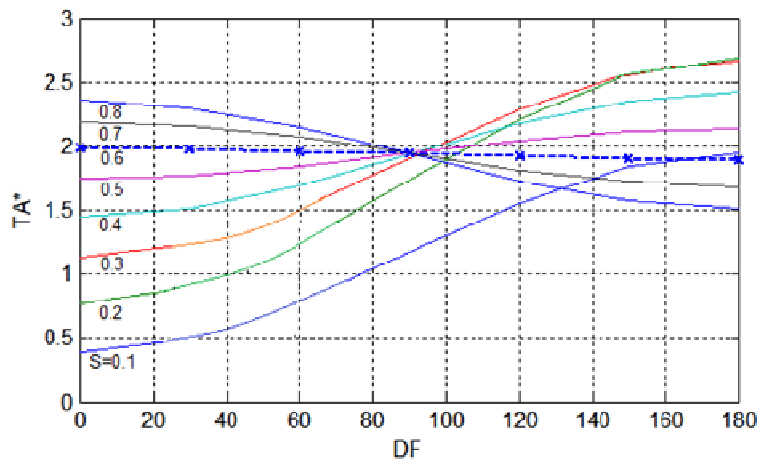

Fig. 6. Maximum asynchronous torque for (ES) versus synchronous angle

## VI. MINIMUM LOAD

The minimum load represents the minimum required load torque to smoothly complete the synchronization process. Minimum load depends on both maximum synchronous and asynchronous torques; and it may be found as follows:

$$T_L = (T_{asy} - T_{sy}) / 2 \quad (17)$$

The required minimum torque may be found as:

$$T_L = A + B \cos \alpha - D \sin \alpha \quad (18)$$

Fig. 7 illustrates the mentioned minimum torque for all three synchronization systems ES, EMS, and EMSC. Fig. 7 shows that for slip values less than 0.55, the best system is ES as it does not require any minimum load to achieve the synchronization process.

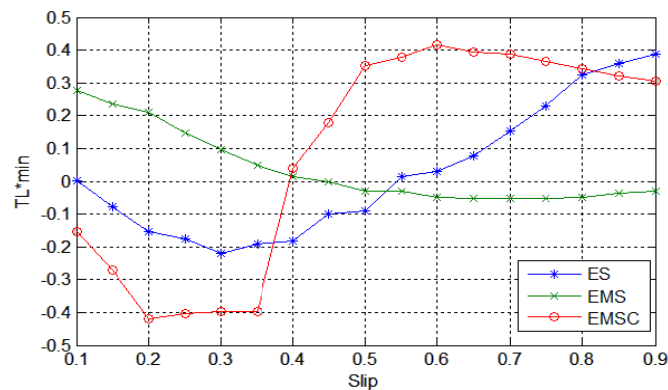

Fig. 7. Minimum load versus slip

## VII. CONCLUSION

In the present work, a comprehensive comparative study between three different approaches for two-motor traditional synchronization systems has been conducted. Different indicators of three synchronization systems were studied, modeled, calculated and discussed. The three studied synchronization systems are: electrical shaft, electromagnetic shaft, and capacitor-electromagnetic shaft. The results show that the best system in terms of the studied indicators (maximum synchronous angle, minimum load, maximum synchronous torque, and maximum asynchronous torque) at low slip is the electrical shaft system. The main disadvantage of this system is power losses.

The best system in terms of the studied indicators at medium slip is the capacitor-electromagnetic shaft synchronization system. The main disadvantage of this system is its large size and high cost. The achieved results will help the electric drive designer to choose the best approach of synchronization systems for certain applications.

## APPENDIX

Induction motors parameters:

5hp, 50Hz, 4 poles, 380V line voltage,

$R_1 = 1.115\Omega$ ,  $X_1 = 2.252\Omega$ ,  $R_2 = 1.083\Omega$ ,  $X_2 = 2.252\Omega$ ,  $X_\mu = 76.8\Omega$ ,  $R_\mu = 2.42\Omega$ ,  $J = 0.02\text{kg.m}^2$ .

Inductive element parameters:

$R'_M = 2.564\Omega$ ,  $R'_o = X'_o = (0.1 - 0.2) R'_M$ ,  $X_M = (0.6 - 0.7) R'_M$ .

**REFERENCES**

- [1] E. S. Addasi, "Modelling and simulation of ac electric drive control system with variable moment of inertia," *International Journal of Modelling, Identification and Control*, vol. 14, no. 3, pp. 170-177, 2011.
- [2] E. S. Addasi, "High-slip induction motor with additional rotor moving along the axis," *European Journal of Scientific Research*, vol. 87, no. 3, pp. 406-411, 2012.
- [3] S. Lekhchine, T. Bahi, H. Bouzeria and S. Lachtar, "Robust sliding mode speed controller for induction motor drive system," *International Journal of Industrial Electronics and Drives*, vol. 2, no. 2, pp. 84-90, 2015.
- [4] V. Chauhan and V. P. Patel, "Multi-motor synchronization techniques," *International Journal of Science, Engineering and Technology Research*, vol. 3, no. 2, 2014.
- [5] A. Shukla, A. Kumar, A. K. Rajak, V. K. Singh and S. Santhosh, "Speed synchronization of multiple dc motors in textile & paper mills using micro controller," *International Journal of Engineering Research and Applications*, vol. 5, no. 5, pp. 52-55, 2015.
- [6] Z. Bin, G. Feng and L. Tian, "Normalized coupling method for speed synchronization of multi-axis driving vehicles," *International Journal of Advanced Robotic Systems*, vol. 9, no. 50, pp. 1-10, 2012.
- [7] W. Chen, Y. Wu, R. Du, Q. Chen and X. Wu, "Speed tracking and synchronization of a dual-motor system via second order sliding mode control," *Mathematical Problems in Engineering*, vol. 2013, pp. 1-10, 2013.
- [8] A. S. Akayleh, "Mathematical model of resistor effect on the synchronization systems," *Far East Journal of Dynamical Systems*, vol. 12, no. 1, pp 41-53, 2010.
- [9] A. S. Akayleh, A. Samarai and M. Al-Soud, "Mathematical model of inductive effect on the multi-motors synchronization systems," *Jordan journal of Mechanical and Industrial Engineering*, vol. 3, no. 2, pp. 151-156, 2009.
- [10] A. S. Akayleh, "Mathematical model of capacitor effect on the synchronization systems," *European Journal of Scientific Research*, vol. 32, no. 1, pp. 34-42, 2009.
- [11] Z. Zhang, K. T. Chau and Z. Wang, "Chaotic speed synchronization control of multiple induction motors using stator flux regulation," *IEEE Transaction on Magnetics*, vol. 48, no. 11, pp. 4487-4490, 2012.
- [12] D. Zhao, C. Li and J. Ren, "Speed synchronization of multiple induction motors with adjacent cross coupling control," *28<sup>th</sup> Chinese Control Conference Shanghai*, pp. 6805-6810, 2009.
- [13] P. Francisco, C. Nunez, R. Alvarez and I. Cervantes, "Comparison of multi-motor synchronization techniques," *Annual Conference of the IEEE Industrial Electronics Society*, vol. 2, pp. 1670-1675, 2004.
- [14] C. W. Chuang, C. L. Haung, C. D. Lee, C. C. Kao and R. F. Fung, "Synchronization and tension control of dual motor systems via MIMO discrete pseudo model following integral variable structure control," *Mechanism and Machine Theory*, vol. 44, no. 2, pp. 499-510, 2009.
- [15] P. H. Chou, C. S. Chen and F. J. Lin., "DSP-based synchronous control of dual linear motors via Sugeno type fuzzy neural network compensator," *Journal of the Franklin Institute*, vol. 349, no. 3, pp. 792-812, 2012.



- [16] Y. Xiao and K. Y. Zhu., "Optimal synchronization control of high-precision motion systems," *IEEE Transactions on Industrial Electronics*, vol. 53, no. 4, pp. 1160-1169, 2006.
- [17] A. S. Akayleh, "Speed synchronization of single-phase induction motors by electrical shaft system," *Jordan Journal of Electrical Engineering*, vol. 1, no. 1, pp. 37-44, 2015.
- [18] O. Hadjaev and M. Sagitov, *Theory and Methods of Multi-Motors Alternating Current Synchronous Rotation Drives*, Soviet Union, Power Engineering. 1989.
- [19] G. T. C. Chiu and M. Tomizuka, "Coordinated position control of multi-axis mechanical systems," *ASME Journal of Dynamic Systems, Measurement and Control*, vol. 120, no. 3, pp. 389-393, 1998.
- [20] F. J. Lin, H. J. Hsieh, P. H. Chou and Y. S. Lin, "Digital signal processor-based cross-coupled synchronous control of dual linear motors via functional link radial basis function network," *IET Control Theory and Applications*, vol. 5, no. 4, pp. 552-564, 2011.
- [21] F. G. Moritz, *Electromechanical Motion Systems Design and Simulation*, John Wiley & Sons, 2014.
- [22] S. E. Lyshevski, *Electromechanical Systems and Devices*. Taylor & Francis Group, 2008.
- [23] C. Zhang, H. Wu, B. Liu, J. He and B. Li., "Hybrid structure based tracking and consensus for multiple motors," *Mathematical Problems in Engineering*, vol. 2014, pp. 1-9, 2014.
- [24] Y. Xiao, Y. Pang, X. Ge and J. Sun, "Synchronous control for high-accuracy biaxial motion systems," *Journal of Control Theory and Applications*, vol. 11, no. 2, pp. 294-298, 2013.
- [25] N. Mitrovic, V. Kostic, M. Petronijevic and B. Jeftenic, "Multi-motor drives for crane application," *Advances in Electrical and Computer Engineering*, vol. 9, no. 3, pp. 57-62, 2009.